

Empire is an approved provider of 3M™ Double Sided Tape products. Working from blueprints, we can convert 3M™ VHB™ Tapes into any length, shape, or size to fit your desired needs with our die and laser cutting processes.

VHB™ is perfect for electronics or appliances as it has high viscoelasticity which aids in bonding dissimilar materials. It has strong energy absorption, water tight sealing, and virtually invisible fastening which will make your product stand out even more.

As seen on TVs Modern Marvels, 3M demonstrated the incredible holding power of 3M™ VHB™ Foam Tape. For over 35 years, industries worldwide have been using it to permanently bond and seal substrates for increased productivity, high strength, long term durability, and improved aesthetics.

WHAT IS VHB™?

The 3M™ VHB™ Tape family consists of foam tapes and adhesive transfer tapes containing a solid acrylic adhesive with closed cell technology.

HOW DOES VHB™ WORK?

These tapes work by absorbing and dissipating energy by the foam core. The foam also protects the bond by dispersing the stress into the foam.

WHERE IS VHB™ USED?

Applications with outdoor use, severe/extreme environments, or dynamic forces as well as applications where exceptional performance is desired, where a premium seal is required, or where convenience is a requirement.



FEATURES, ADVANTAGES, AND BENEFITS:

STRENGTH

- Static or dynamic stress
- Distributes stress over entire surface
- Absorbs shock and flexing
- Eliminates pull through, dimpling, and weld distortion
- Every pound of weight needs four square inches of VHB™

DURABILITY

- Resists high temperature, cold temperature cycling, UV light, moisture, and solvents
- Seals against environmental conditions
- Prevents bi-metallic corrosion
- Damp vibration to prevent metal fatigue
- Compensates for thermal expansion

PRODUCTIVITY

- Saves money and time
- Pressure sensitive adhesive (PSA) bonds on contact
- Fast and easy assembly
- Eliminates time consuming labor: Drilling, grinding, refinishing, screwing welding, and clean-up

APPEARANCE

- Virtually invisible fastening
- Allows for use of lighter weight and thinner materials
- Uniform thickness

P/N: 2000841_133793_VHB_2023



Choose 3M™ VHB™ for bare or painted metal.

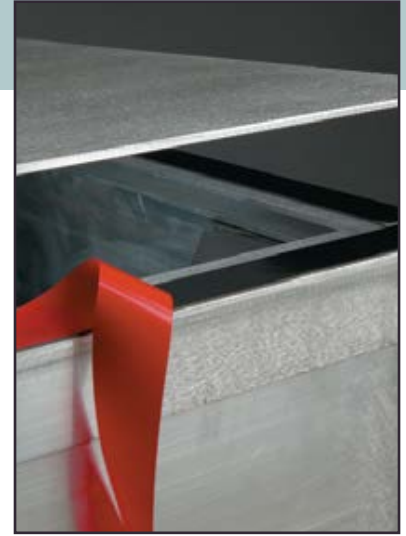
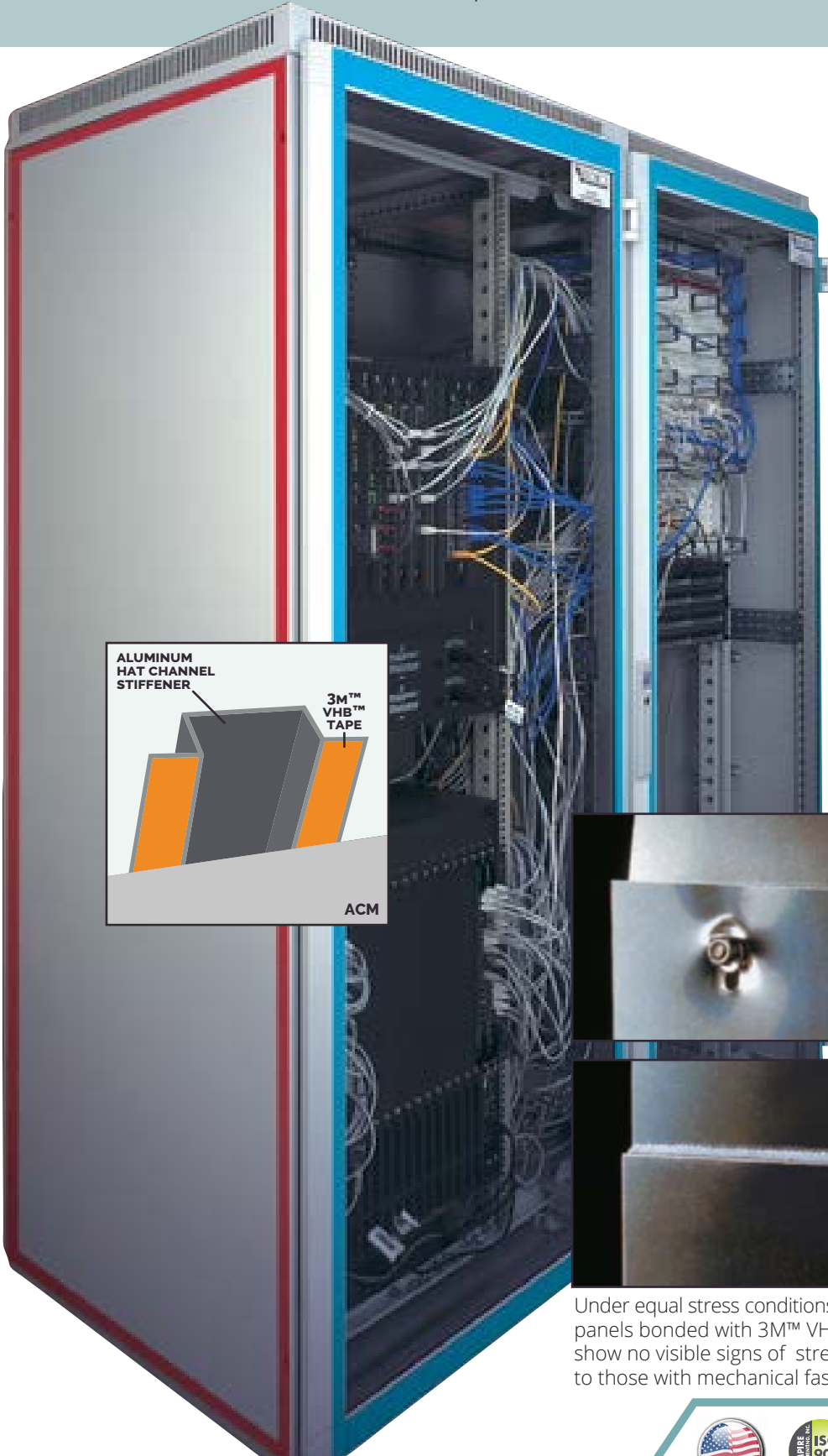

Permanently bond metal skin to enclosure frame.



Permanently attach brackets and stiffeners.



Permanently attach plastic pocket to enclosure panel without priming in most applications.



Under equal stress conditions, metal panels bonded with 3M™ VHB™ Tape show no visible signs of stress compared to those with mechanical fasteners.



Flexibility to meet rigid standards of the electronics industry.



A precise fit with die-cut 3M™ VHB™ Tape.

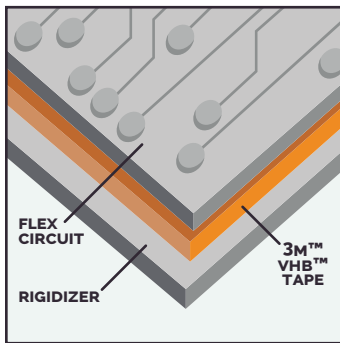

Bond rigidizer to flex circuit and withstand process heat.



Bond and weather-seal a fish finder lens.

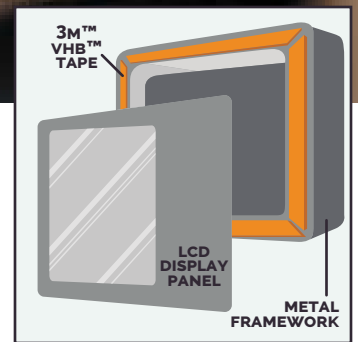

Versatility and reliable performance throughout any sign.

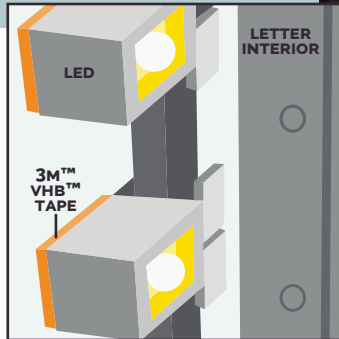

Channel letter sign with decorative backdrop. **Seattle, Washington**

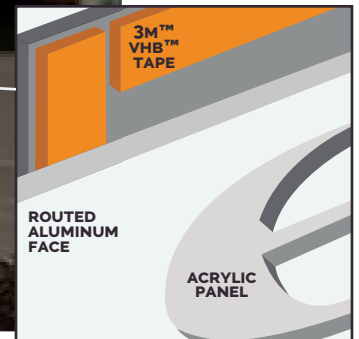
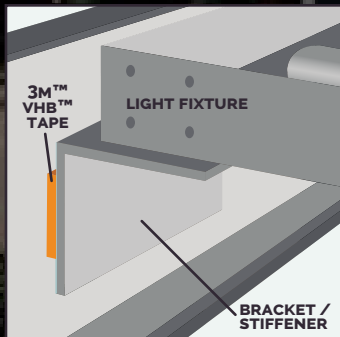
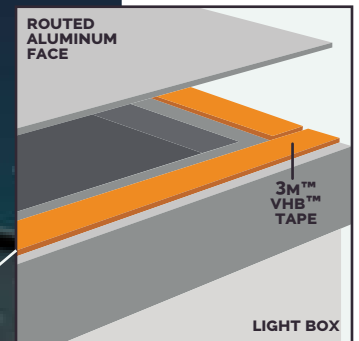
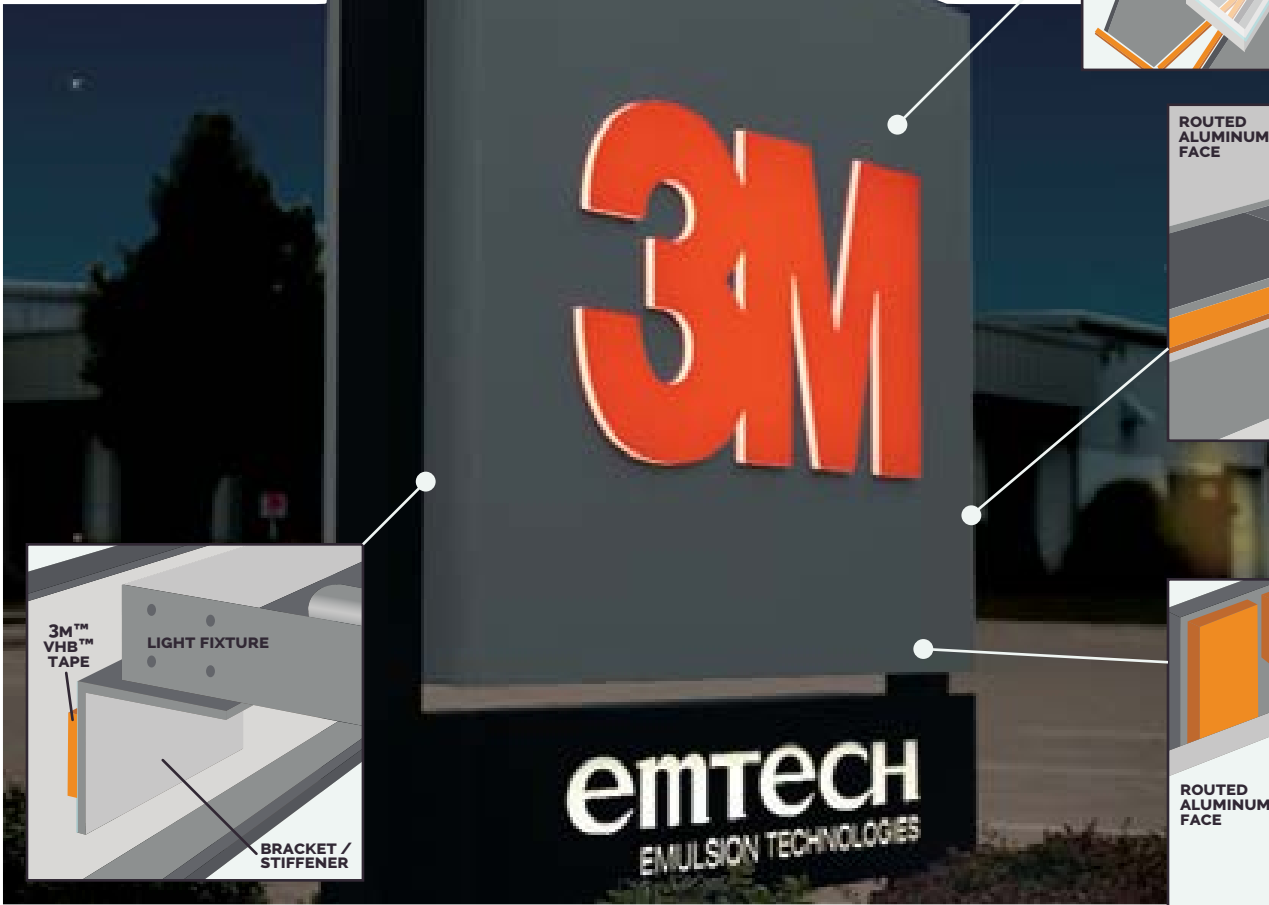
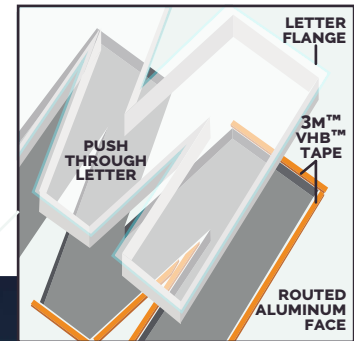
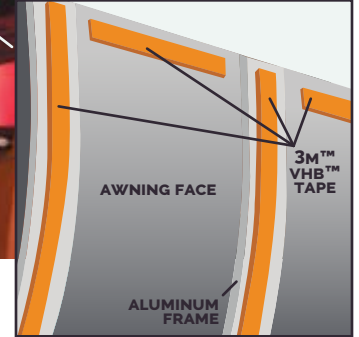

Fabricator: Lawrence Sign, 2003 — Medina, Ohio
Twin pole monument sign.



METAL FABRICATION

- Appliances
- Transportation
- Trailers

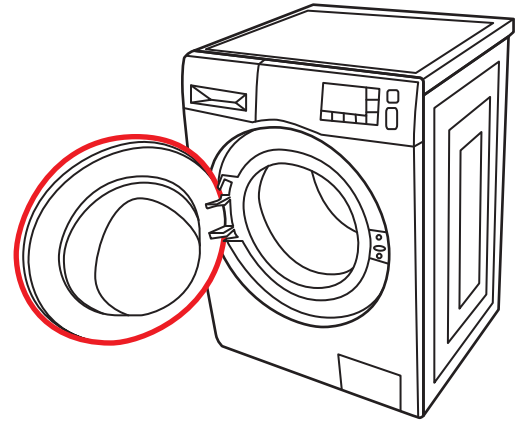
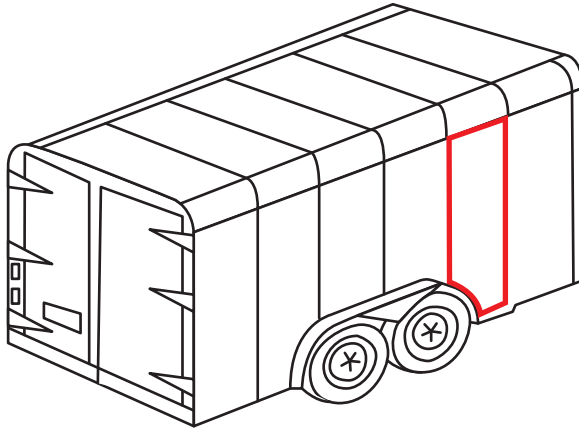

ELECTRONICS

- Cameras
- TV
- Mobile Phone
- Stereo Equipment

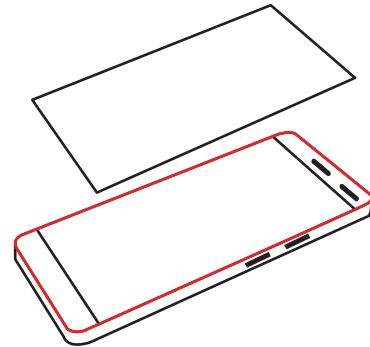
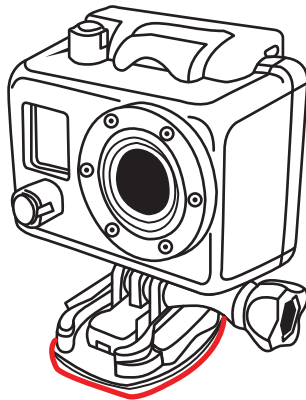

OUTDOOR SIGNS



CREDITS

© 3M and VHB are trademarks of 3M.

For more information about 3M™ VHB™ Tapes, please visit www.3M.com or www.empirescreen.com.

Resources:

VHB Design Guide.pdf (©2005)

3m-vhb-tape-design-guide-high-res-pdf (© 2016)

